

A Special Trip for Alec

Priming

Write the answers to the questions below or use the blue phrase strips to fill in the answers.

Before you read the story, look at the title of the story.

1. **What** is this story about? This story is about

Alec going on a special trip

Before you read the story, look at the pictures in the story.

2. **Who** is Alec? Alec is a

boy

3. Look at Alec's face in the picture on page 55. **How** does Alec feel? Alec feels

bored

4. Look at Alec's face in the picture on page 56. **How** does Alec feel? Alec feels

5. Look at Alec's face in the picture on page 57. **How** does Alec feel? Alec feels

6. **What** is Alec putting in his backpack that will help him see in the dark? Alec is putting in

7. **What** food is Alec taking? Alec is taking



A Special Trip for Alec

Vocabulary

Before you read the story, find the picture for each word in the box.

apartment building
backpack

flashlight
fruit snacks

notebook
zipper bag

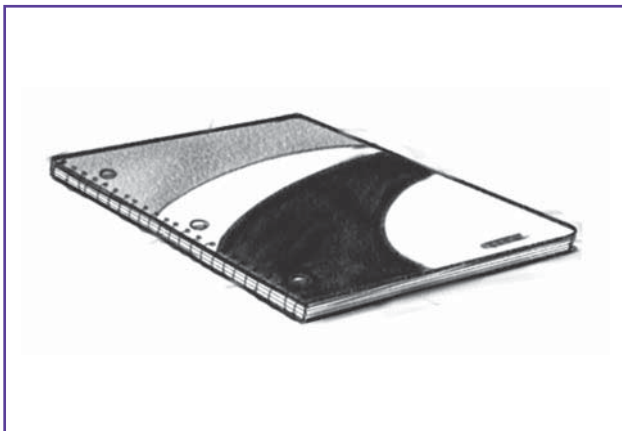
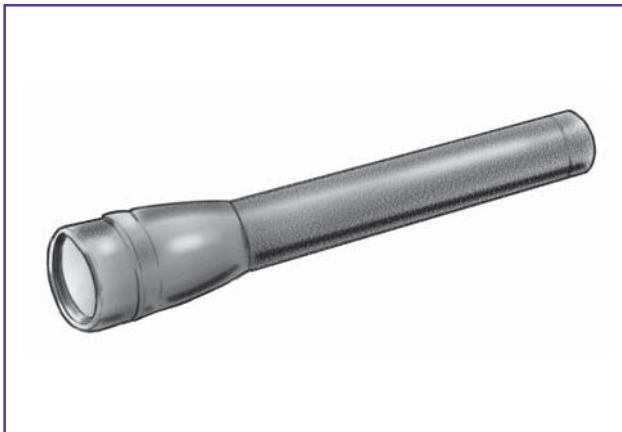
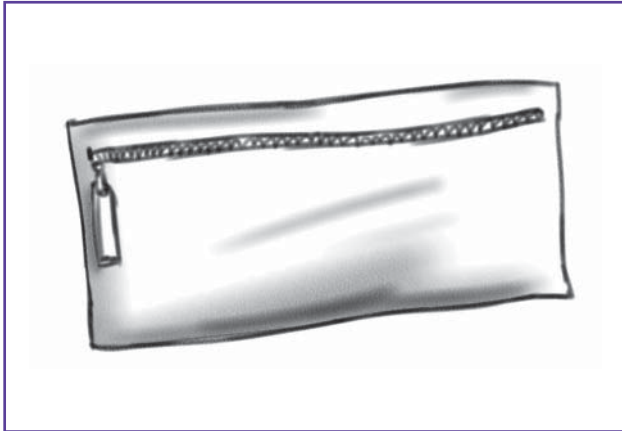

A Special Trip for Alec

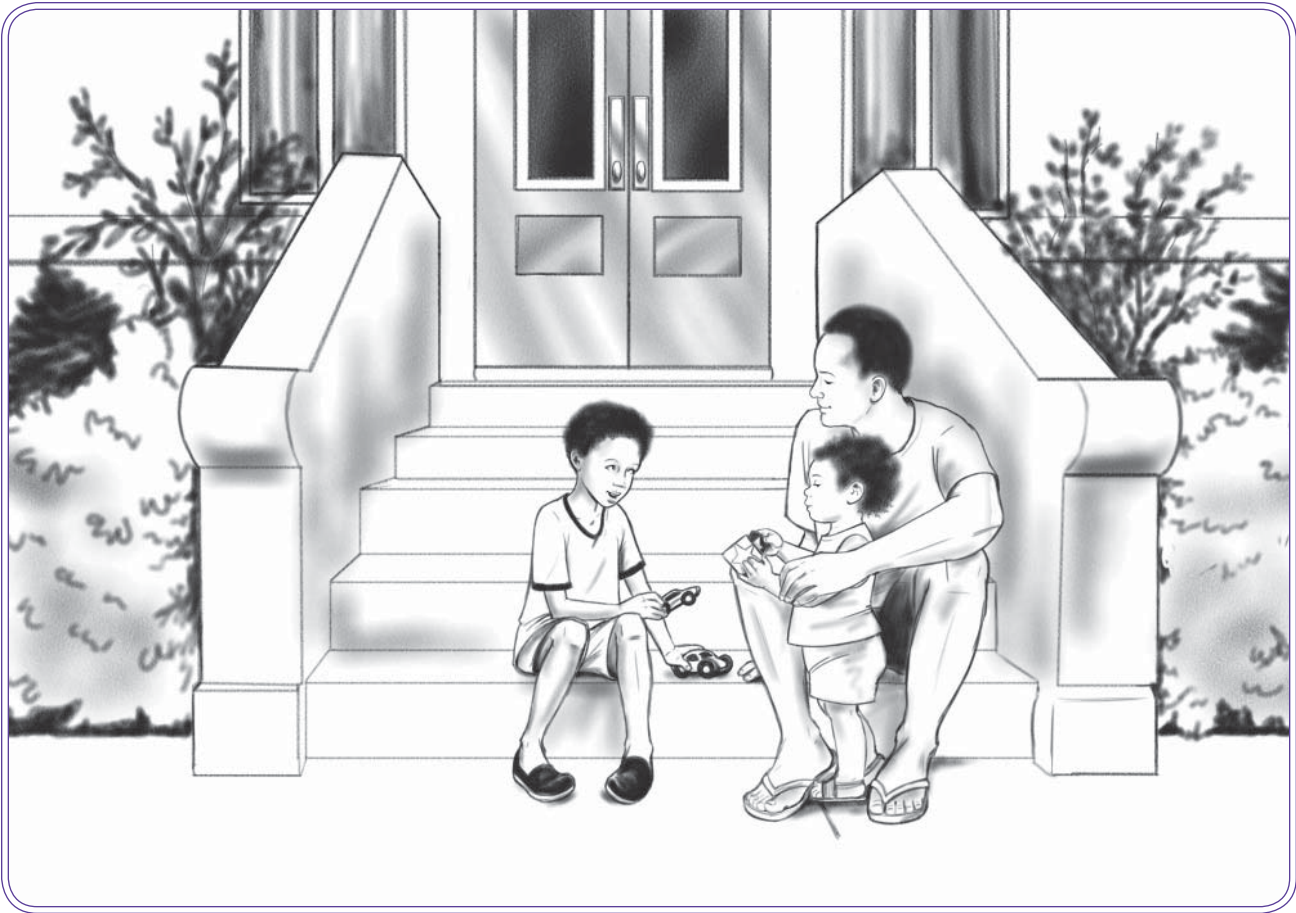

It is a hot summer day. Alec is playing with his cars in front of his apartment building. His father is sitting on the steps, holding baby James.

“I’m tired of playing with my cars, Dad,” says Alec. “I want to go to the park and play on the swings.”

“Sorry, Alec,” his father says. “Your brother needs his nap. Maybe we can go later.”

It looks like Alec lives in the city. He really wants to play at the park.

A Special Trip for Alec, *continued*

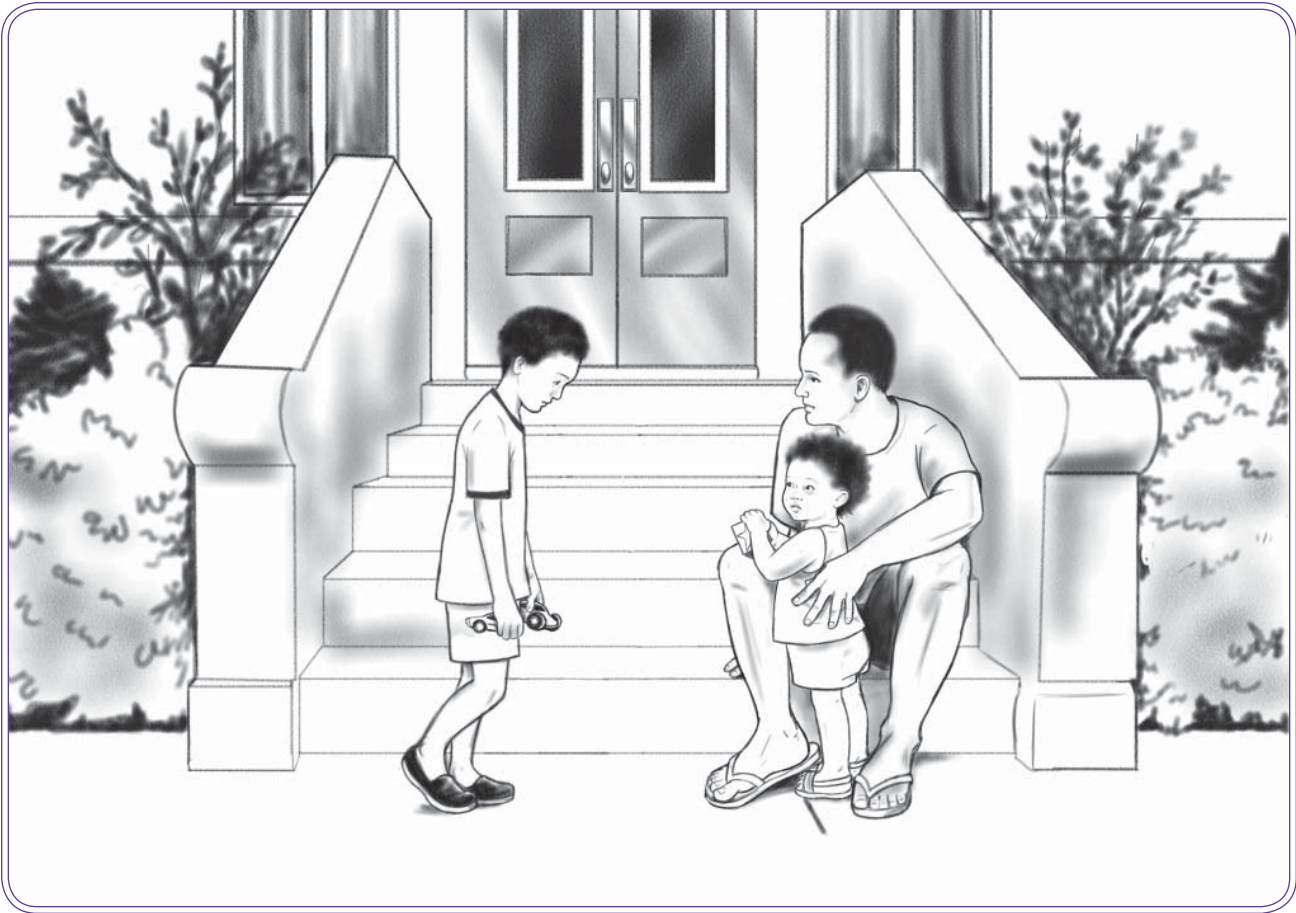

Alec is sad. He shuffles his feet on the sidewalk. He says, "I don't want to stay here. I want to go all by myself."

Alec's father smiles. "I know you want to go, but you can't go to the park alone," he says. "I have an idea. You can go on an expedition to the end of the block. You can go all by yourself."

It wouldn't be safe for Alec to go to the park by himself.

A Special Trip for Alec, *continued*

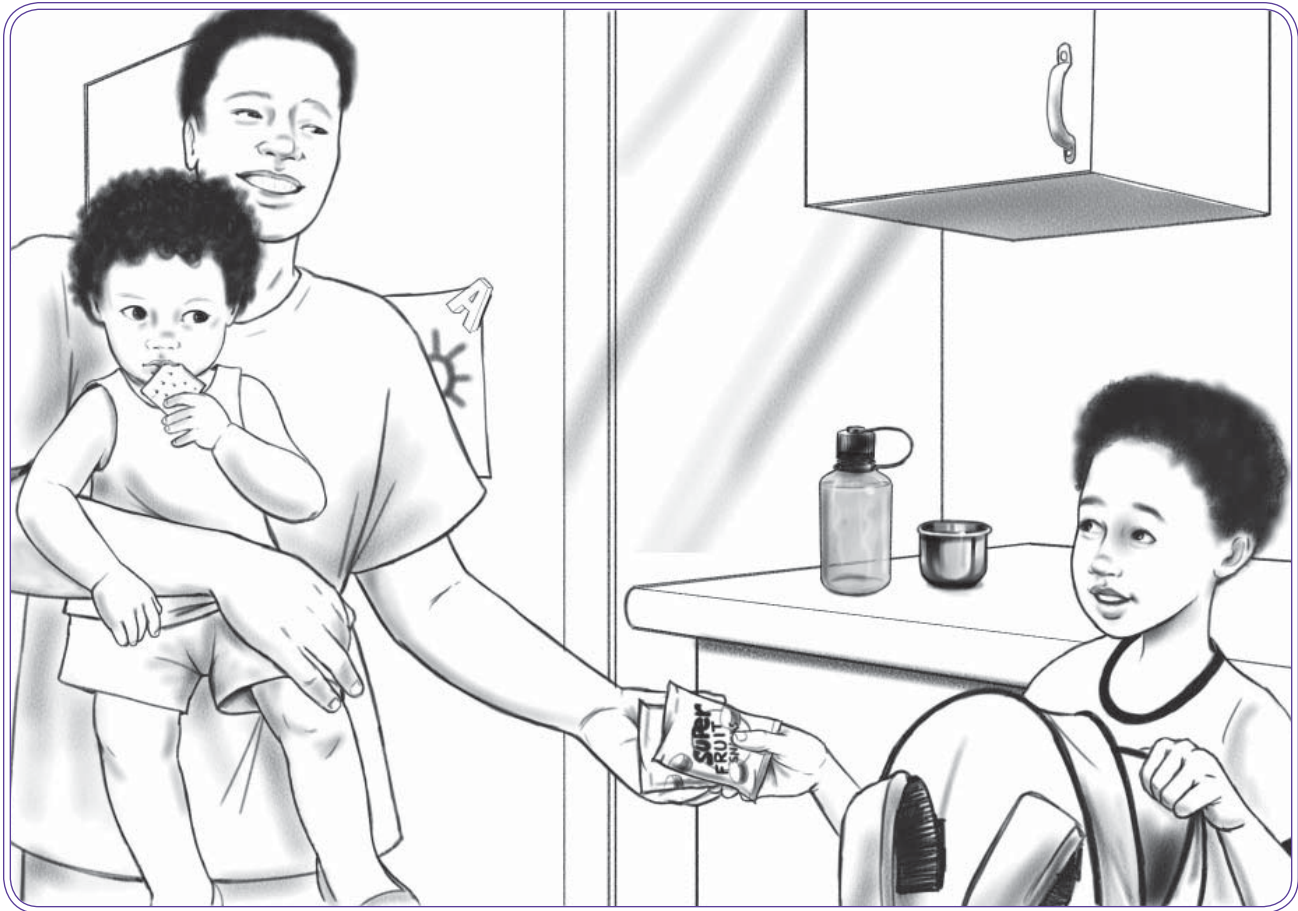

Alec and his father go to the kitchen.

“Take some fruit snacks to eat along the way. And, you may get thirsty. Here is a bottle of water and a cup. These things are called provisions,” explains his father. “You need provisions for your expedition.”

“I need provisions for my expedition,” sings Alec. “I am ready to go!”

Alec puts on his backpack and goes out the door.

Provisions for his expedition — Alec’s father has a good idea! Alec can use all those things on his expedition.

A Special Trip for Alec

Basic Story Analysis

Write the answers to the questions below or use the green phrase strips to fill in the answers.

1. **What** was this story about? The story was about

[-----]
[-----]

2. **Who** were the people in the story? The people in the story were

[-----]
[-----]

3. **What** did Alec want to do? Alec wanted to

[-----]
[-----]

4. **What** was the father's idea? The father's idea was

[-----]
[-----]

5. **Where** was Alec's backpack? Alec's backpack was

[-----]
[-----]

6. **What** did Alec take to drink? Alec took

[-----]
[-----]

A Special Trip for Alec

Pronoun Referents

In stories, we use words like **she**, **he**, **her**, **him**, **we**, **they**, **them**, **it**, **our**, and **their** instead of saying the name of a person, place, or thing. Here are some sentences from this story. The pronouns, or short-cut words, are printed in purple. Draw a line from each purple word to the person(s) or thing(s) it refers to in the sentence. Here is an example:



Alec is playing with **his** cars in front of **his** apartment building.

The diagram shows two curved arrows. One arrow starts at the purple word "his" before "cars" and points to the word "Alec" at the beginning of the sentence. The other arrow starts at the purple word "his" before "apartment building" and points to the word "Alec" at the beginning of the sentence.

1. "Sorry, Alec," **his** father says. "**Your** brother needs **his** nap."
2. Alec is sad. **He** shuffles **his** feet on the sidewalk.
3. (Alec's father is talking to Alec.) "Let's go inside and get **your** backpack. **We** will fill **it** with things **you** may need for **your** expedition."
4. Alec runs to **his** room to get **his** backpack. "What should **I** put in **my** backpack?" **he** asks.
5. "**I** need provisions for **my** expedition," sings Alec. "**I** am ready to go!"